Floorboards and finished floorboards

Ordering, transport, storage, installation, maintenance

GUIDE

1. Ordering	2
1.1. Choosing the wood specie	2
1.2. Choosing a profile	2
1.3. Why order industrially finished floorboards – pros and cons. What should be held in mind when ordering?	3
2. Transport and storage	3
2.1. Transport	3
2.2. Storage	4
3. Installation	4
3.1. Methods for installing floorboards	4
3.2. Fastening devices and fastening	5
3.3. Connecting ends and corners; joints	5

*(For quality specifications see Puidukoda quality description “Interior panelling and floorboards AB”)

1. Ordering

1.1. Choosing the wood specie

Either pine or spruce floorboards can be ordered. When making your choice, give the visual differences primary consideration. A pine wood floor has a reddish tone and darker and larger knots, which will get even darker over time. Spruce floors are lighter, the knots are less visible and generally smaller; the wood becomes more yellowish over time.

1.2. Choosing a profile

Puidukoda offers different flooring profiles from spruce and pine. Both spruce and pine floorboards

with moisture content 12% and with moisture content 16% are available with bevelled edges or with sharp corners (without bevel). End matching is possible by request.

Newly installed unfinished Puidukoda floorboards must be sanded to minimize imperfections and to prepare the floorboards for the finishing. We suggest that you carefully follow the manufacturer's instructions on the finishing product you choose.

Floorboards with bevelled edges

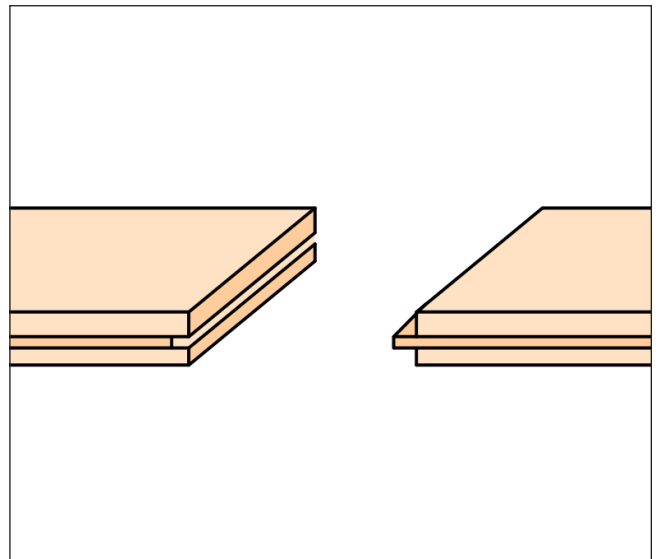
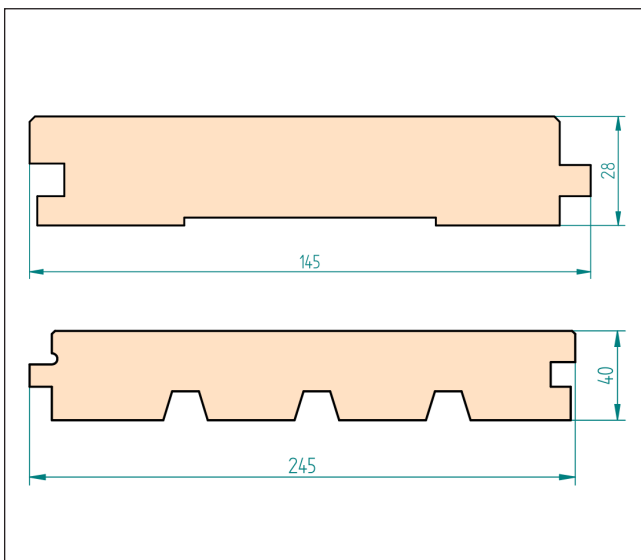

Floorboards with sharp corners (without bevel)

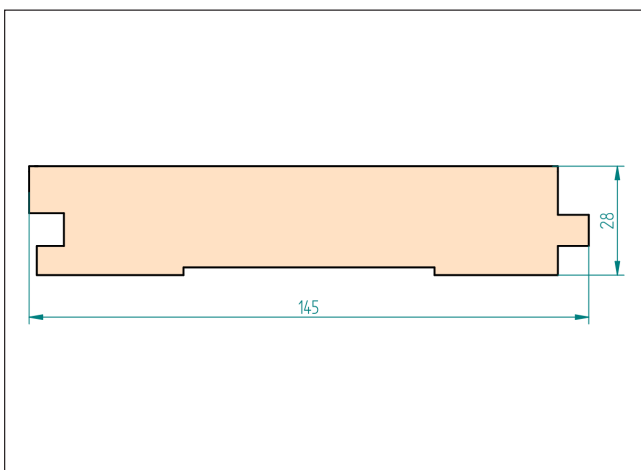

1.3. Why order industrially-finished floorboards – pros and cons. What should be held in mind when ordering?

Floorboards with industrially applied large variety of finishes can be ordered from Puidukoda. The manufacturing of the floorboards takes place in interior facilities, in a dust-free environment at a consistent temperature and relative humidity. The finishes are applied according to manufacturer's instructions and to the required thickness, whereas board finishing systems approved by the coating manufacturer are used. **This guarantees a high-quality and durable long-lasting result.**

Also, in terms of price, factory finished floorboards are less expensive than do-it-yourself finishes, because manufacturers enjoy lower purchase prices in bulk and the labour costs per unit are much lower thanks to the efficient, mechanized production.

Drawbacks are undoubtedly the facts that there is an optimum quantity for factory finishing and the options for factory-finished floorboards are limited to varnishes, tinted varnishes and wood stains. Factory-oiled floorboards are not available for order from Puidukoda. In the sense of the manufacturing process and calibrating machinery, it makes good economic sense to coat a minimum of 100 m² of floorboards using one product. Finishing less than 100 m² is **irrational and arduous** for finishing manufacturers **and thus the price is higher as well.**

As delivery times for factory finished products mostly range up to 14 days, this is not a major drawback compared to doing it oneself. Those tackling the project themselves will have to buy the material, varnishes, stains and tools, equip a workbench, allow for drying time on-site, **and all this may not necessarily result in a faster completion time than buying finished floorboards.**

Besides the price (if one tallies up all the costs, including time outlay), the major minus of applying the surface coat oneself is that while painting on-site, it is hard to ensure that the surface coat dries in a stable fashion and has an even appearance.

The lifespan of a floorboard hand-finished in an indoor environment is not guaranteed as besides a suitable work environment, the thickness of the varnish coat must be ensured, something that is hard to achieve using a hand paintbrush or roller. Leaving too little time between varnish coats runs the risk that the lower coat will not be dry enough and the topcoat will not adhere sufficiently well, leading to peeling sooner or later.

A floorboard finished at Puidukoda is a ready to install product that needs no additional workup after installation. It is possible to choose floorboards with colourless/transparent varnish or boards finished with a stain in the tone desired by the customer + varnish. Varnish-coated floors are better able to withstand wear, and easier to clean. The varnish ensures more effective protection against UV radiation, mould and rot. Varnished floorboards are available from us in transparent, silken and glossy finish, and finished with a varnish mixed with a tone selected from a glaze catalogue.

Choose the colour tone carefully. **Keep in mind that the colour tone on the colour chart will vary to a greater or lesser extent from the result,** because the colour chart is only the colour printed on paper and will have a different level of glossiness and refractiveness from the actual colour applied to the wood. Thus, if you are unsure about which colour tone to choose or want 100% accuracy, please settle for a longer delivery term and order sample pieces of wood with the actual colour on them. The risk of getting a colour other than one on the colour chart is greater if the selected tone is not from the tone manufacturer's (Teknos) own colour catalogue.

2. Transport and storage

2.1. Transport

Puidukoda will package the product into packages intended to be picked up from one side using a forklift. **If the trucks or containers are backloaded, there is a high risk of damage to the package or the goods inside.** To avoid damage to the goods when transported in the original Puidukoda packaging, a forklift should be used. **If a crane with a sling is used to load the goods, special harness meant for wood packages must be used.** If using slings, a rigid metal or wooden crossbar must be placed between the slings and the container to **avoid the slings from scoring the corners of the package and causing deformation to**

the wood – in particular to the tongues and grooves of siding boards – due to the pressure from the sling. Although the original packaging is covered with weatherproof plastic film, transport vehicles with an **enclosed compartment should nevertheless be used for transport.** The more the goods are lifted and transported before final installation, the greater the risk of damage during transport.

When off-loading the floorboard package at the construction site, use either a forklift or crane. **Manual on and offloading runs an extremely high risk of damaging the material.**

2.2. Storage

It is highly advisable to store floorboard packages **indoors**. If this is not possible, the boards may be stored outdoors only under a roof, in a ventilated place protected from the elements. When storing the material on the construction site, **examine the film covering the stack and make sure that it has no holes in it or other damage** that could have occurred during storage, loading or transport. If the film is broken, **it should be repaired or replaced with a new one**. **When storing the stack in outdoor condition, cover the top of the stack and all four sides to avoid moisture intruding from the top and sides and also protect the material from UV radiation.**

Leave sufficient airspace under the stack by using base supports. By no means **should the material be in direct contact with the ground**. **The recommended airspace should be about 150 mm.**

The shrink-wrap film the boards are wrapped in at Puidukoda has microperforations to ensure the optimum moisture regimen in the shrink-wrapped small packages. Thus the shrink-wrap is not waterproof and the wrapped stacks must always be also wrapped in packaging film. **If you see that moisture or water has entered** the shrink-wrapped mini-package, the film packages must immediately be opened to ensure sufficient air flow and avoid mould and rot from growing in the individually wrapped packages.

3. Installation

Before installation, the packaged floorboards must adjust to the indoor climate on the premises for at least 14 days as the material must be accustomed to the same moisture conditions of the indoor space. After a minimum two weeks, the acclimatized wood can begin to be installed. If a wood floor begins to be installed in a condition that is quite different from the moisture level of the room, undesirable cracks and tensions may arise between the boards. The relative humidity in the room prior to installation, during installation and after installation must be between 35-60%. If the room's humidity is higher than 60%, the humidity must be lowered and if it is less than 35% it must be raised before installation and storage of the boards. It is not advisable to install wooden floorboards on a heated subfloor as the heated surface will significantly raise the risk of the wood shrinking and cracks forming during the heating period. The finished floorboards in the Puidukoda product selection

do not need any sanding after installation. However, newly installed unfinished Puidukoda floorboards must be sanded to minimize imperfections and to prepare the floorboards for the finishing.

3.1. Methods for installing floorboards

Wooden flooring is fastened to a subfloor, joists or the beams of the ceiling below it. The location of the wooden floor must be level (it cannot deviate more than +/- 2mm per 2-metre's). When fastening floorboards to joists and beams, the spacing between the joists must be in proportion with the thickness of the floorboards. For a 28 mm thick floorboard, the joists must be installed advisably 400 mm apart, and a maximum of 600 mm apart; and a 40 mm thick floorboard requires joists to be installed advisably 600 mm apart and a maximum of 900 mm apart.

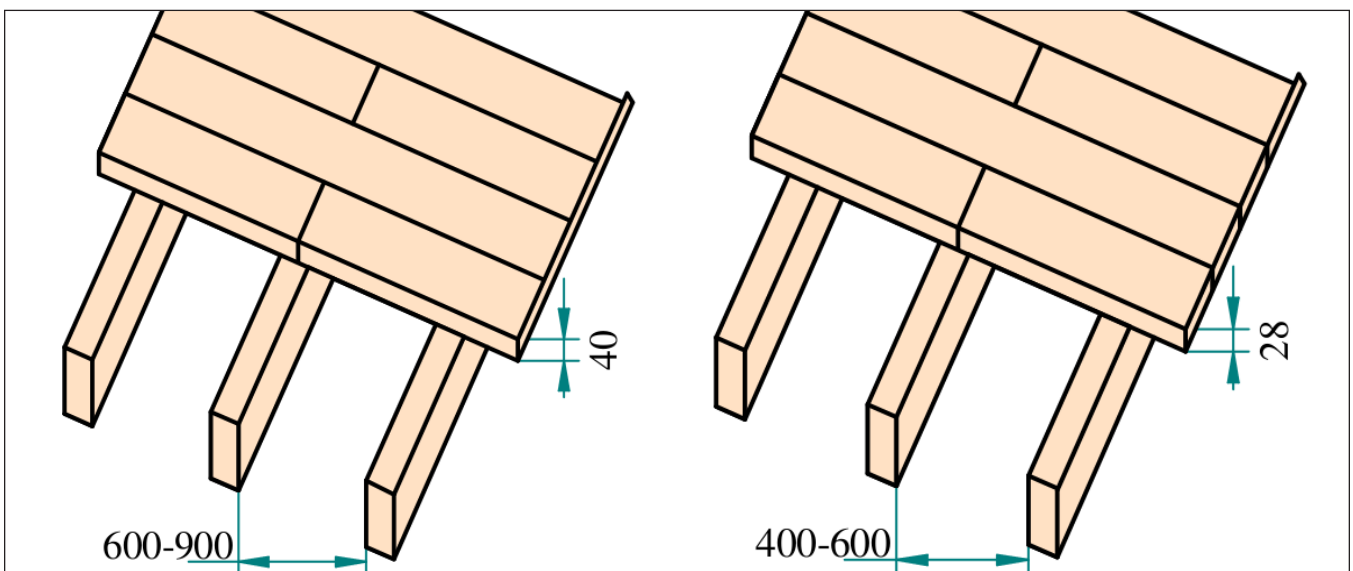

3.2. Fastening devices and fastening

Screws should be used to install wood flooring. Screws allow for easier adjustments to the position of the floorboards and easier dismantling. But be sure to use screws specially intended for flooring installation, where the threaded part penetrates only the joist.

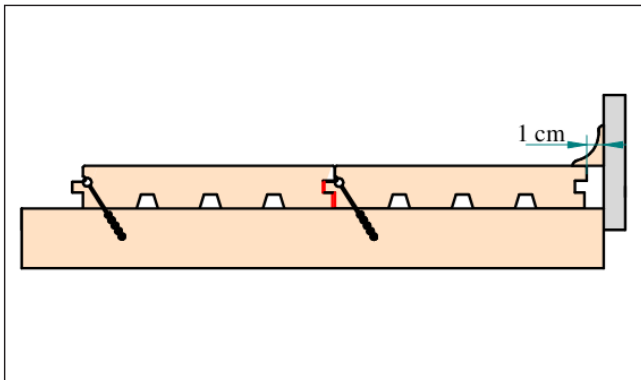

3.3. Connecting ends and corners; joints

Because wood is a natural material that expands as moisture content increases and shrinks when it dries, solid wood flooring should be installed with some space for expansion between the walls and fixed objects (at least 10 mm).

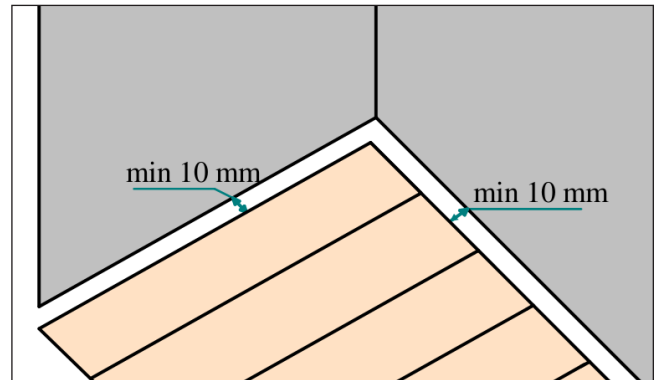

OÜ Puidukoda
 Karksi küla, Mulgi vald, 69104 Viljandi maakond, Eesti
 Tel +372 433 8690
 Faks +372 433 8691
 info@puidukoda.eu



PUIDUKODA
 WOOD FOR LIFE



LE BOIS POUR
 MIEUX BÂTIR



www.puidukoda.eu